

## Model TLC Series

Tension Load Cell (500kg ~ 5t)

The model TLC series, designed for tension measurement and weighing applications, are reliable and easy to install.

- Durable design provide high safety.  
(Ultimate overload rating 500%)
- Alloy tool steel construction for high accuracy.
- Electroless nickel plated for corrosion resistance.

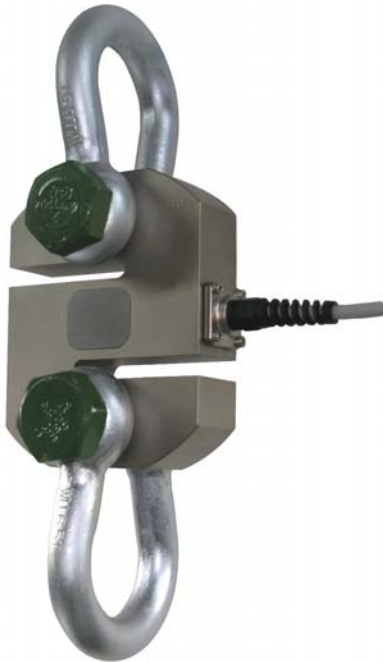

### SPECIFICATIONS

MODEL	TLC
Rated capacity (R.C.)	500kg, 1, 2, 3, 5t
Rated output(R.O.)	1.5mV/V ± 0.25%
Non-linearity	≤0.03% R.O.
Hysteresis	≤0.03% R.O.
Non-repeatability	≤0.03% R.O.
Creep error	≤0.03% in 20min.
Zero balance	≤1% R.O.
Compensated temperature range	-10 ~ 70°C
Operating temperature range	-20 ~ 80°C
Temp. effect on rated output	≤0.05% LOAD/10°C
Temp. effect on zero balance	≤0.05% R.O./10°C
Terminal input resistance	350 Ohms ± 3.5 Ohms
Terminal output resistance	350 Ohms ± 5 Ohms
Insulation resistance (Min.)	2000 MOhms at 50V DC
Excitation voltage	10V(Recommended), 15V(Max.)
Electrical connection	∅7mmx6m(22AWG x 4Core Shielded)
Protection class	meets IP 67
Safe overload	150% R.C
Ultimate overload	500% R.C

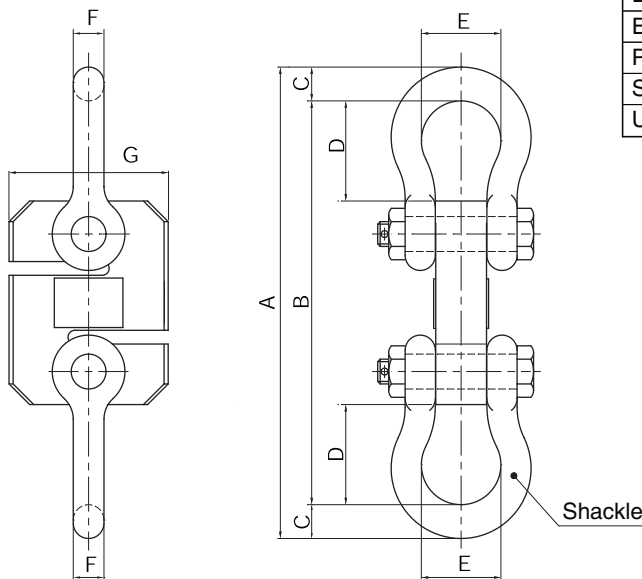

### ORDERING INFORMATION

**TLC - 2T**  
 MODEL CAPACITY  
 500kg, 1, 2, 3, 5ton  
 TLC : Load Cell + Shackle

### WIRING INFORMATION

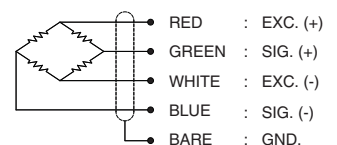

### Dimension-mm

Rated Capacity	A	B	C	D	E	F	G	Shackle	Weight(kg)
500kg, 1t(4.904kN, 9.807kN)	255	220	17.5	54	42.9	16	78	G-2130, 5/8" "Crosby" or eq. ( )Without shackle	3.2kg(1.8kg)
2t ~ 5t (19.61kN~49.04kN)	342.8	293.6	24.6	72.8	58	22.4	116	G-2130, 7/8" "Crosby" or eq. ( )Without shackle	7.8kg(4.2kg)

\* Specifications are subject to change without notice

DEC, 2010