

Skylift - II series

Crane Scale (1t ~ 5t)

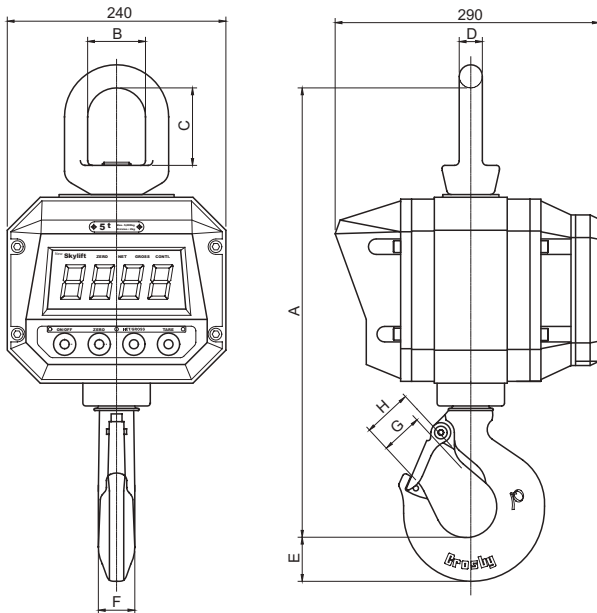

I.R. Remocon



Features;

- Robust design & High accuracy
- Durable cast aluminium housing
- Large brightness LED display(38mm)
- Sturdy swivel hook("Crosby" or equivalent)
- 24bit Sigma-delta A/D converter
- Easy access rechargeable battery
- Watertight push button switch
- I.R. remote control (on/off, zero, net/gross, tare, hold)
- Optional wireless display & controller

SPECIFICATIONS

Model	NCS			
Capacity (Max.)	1000kg	2000kg	3000kg	5000kg
Division (e=d)	0.5kg	1kg	1kg	2kg
Display	38mm height LED, 4 digit			
Power	6 volt lead-acid rechargeable battery			
Battery operating time	80 hours between recharging			
Recharging time	Approx. 4 hours			
Operating temp.	-10°C ~ 50°C			
Enclosure	Cast aluminium, IP64			
Safe overload	150% of rated capacity			
Ultimate overload	500% of rated capacity			
Hook	Swivel hook with thrust bearing			
Switches	On/Off, Zero, Net/Gross, Tare			
Annunciators(LED lamp)	Continuation(Auto power OFF), Zero, Net, Gross			
Accessories	(1) Battery, 6 volt rchargeable (2) Battery charger (Free voltage, AC85~260V) (3) I.R. Type Remocon			
Option	1) Wireless Handy Indicator(Model : BS-52R) 2.4GHz Bluetooth Communication 2) Wireless Desktop Indicator / Large Display			

ORDERING INFORMATION

NCS - **5T**
 MODEL CAPACITY
 NCS 1, 2, 3, 5ton



BS-52R
(Option)

Dimension-mm

Model	Capacity	A	B	C	D	E	F	G (with latch)	H (without latch)	Weight(kg)
NCS - 1T	1000kg x 0.5kg	370	50	63	19	29	24	29.5	30.2	18 kg
NCS - 2T	2000kg x 1kg	448	63	85	25.4	37	29	35.8	38.1	20 kg
NCS - 3T	3000kg x 1kg	448	63	85	25.4	37	29	35.8	38.1	20 kg
NCS - 5T	5000kg x 2kg	480	63	85	25.4	46	37	42.9	45.2	23 kg

Specifications are subject to change without notice

JAN, 2010