

LIFT - ACE

Crane Scale (500kg ~ 2000kg)



Features;

- Lightweight portable scale
- Watertight integrity in the harshest environments (IP64 enclosure) cast aluminium housing
- 80 hours running rechargeable battery
- Sturdy swivel hook ON/OFF, ZERO NET/GROSS, TARE push button switch

SPECIFICATIONS

| Model | ACBE | | |
|------------------------|--|--------|--------|
| Capacity (Max.) | 500kg | 1000kg | 2000kg |
| Division (e=d) | 0.2kg | 0.5kg | 1kg |
| Accuracy | 25mm height LED, 4digit | | |
| Power | 6 volt lead-acid rechargeable battery | | |
| Battery operating time | 80 hours | | |
| Recharging time | Approx. 4 hours | | |
| Operating temp. | -10 °C ~ 50 °C | | |
| Enclosure | Cast aluminium, IP64 | | |
| Safe overload | 150% of rated capacity | | |
| Ultimate overload | 400% of rated capacity | | |
| Hook | Swivel hook with thrust bearing | | |
| Switches | On/Off, Zero, Net/Gross, Tare | | |
| Annunciators(LED lamp) | Continuation(Auto power OFF), Zero, Net, Gross | | |
| Accessories | Battery charger | | |
| Option | 1) I.R. Type Remocon 2) Wireless Handy Indicator(Model : BS-52R) 2.4GHz Bluetooth Communication 3) Wireless Desktop Indicator / Large Display | | |
| Weight | Approx. 7 kg | | |

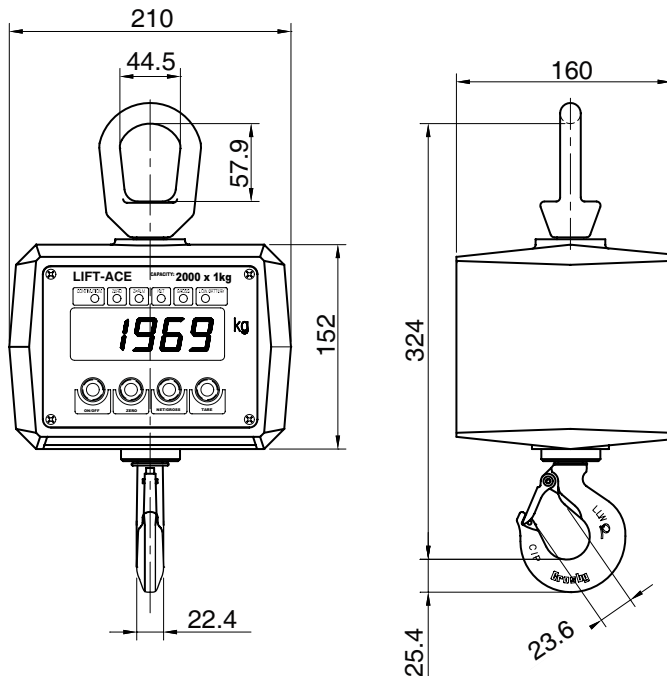

ORDERING INFORMATION

ACBE - 500
 MODEL CAPACITY
 ACBE 500kg
 1000kg
 2000kg

* Specifications are subject to change without notice

JAN, 2010