

Model CWFK Series

Center Hole Type Load Cell
(10t ~ 200t)

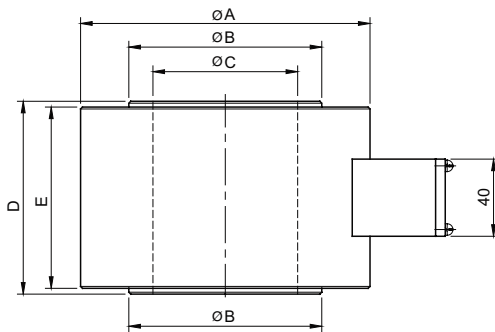
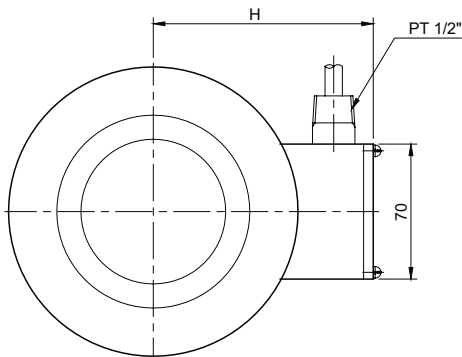

- Robust high capacity design
- Alloy steel construction
- Fully welded seal

SPECIFICATIONS

| MODEL | CWFK |
|-------------------------------|--|
| Rated capacity (R.C.) | 10, 20, 50, 100, 150, 200t |
| Rated output(R.O.) | 1.0mV/V \pm 0.3% |
| Non-linearity | \leq 1.0% R.O. |
| Hysteresis | \leq 1.0% R.O. |
| Non-repeatability | \leq 1.0% R.O. |
| Creep error | \leq 0.1% in 20min. |
| Zero balance | \leq 1% R.O. |
| Compensated temperature range | -10 ~ 70°C |
| Operating temperature range | -20 ~ 80°C |
| Temp. effect on rated output | \leq 0.05% LOAD/10°C |
| Temp. effect on zero balance | \leq 0.05% R.O./10°C |
| Terminal input resistance | 350 Ohms \pm 3.5 Ohms |
| Terminal output resistance | 350 Ohms \pm 5 Ohms |
| Insulation resistance (Min.) | 2000 MOhms at 50V DC |
| Excitation voltage | 10V(Recommended), 15V(Max.) |
| Electrical connection | \varnothing 9mmx5m(22AWG x 4Core Shielded) |
| Protection class | meets IP 67 |
| Safe overload | 150% R.C |
| Ultimate overload | 300% R.C |

ORDERING INFORMATION

CWFK - 50T

| MODEL | CAPACITY |
|-------|----------------------------|
| CWFK | 10, 20, 50, 100, 150, 200t |

WIRING INFORMATION

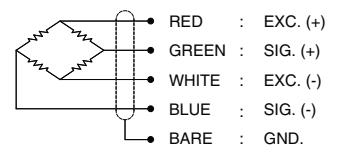

Dimension-mm

| Rated Capacity | A | B | C | D | E | H | Weight (kg) |
|--------------------------|-----|-----|-----|-----|-----|-----|-------------|
| 10, 20t (98.07, 196.1kN) | 88 | 48 | 30 | 80 | 74 | 76 | 1.6 |
| 50t (490.3 kN) | 110 | 70 | 40 | 80 | 74 | 87 | 3.0 |
| 100t (980.7 kN) | 138 | 100 | 60 | 110 | 100 | 101 | 6.2 |
| 150t (1471kN) | 164 | 126 | 80 | 130 | 120 | 114 | 11.6 |
| 200t (1961kN) | 190 | 152 | 100 | 150 | 140 | 127 | 18.0 |

* Specifications are subject to change without notice

JAN, 2010