

## Model CS61 Series

Center hole type load cell (1t ~ 3t)

- Low profile shear type
- Alloy tool steel construction for high accuracy.
- Electroless nickel plated for corrosion resistance.
- Fully sealed to IP67.



### SPECIFICATIONS

MODEL	CS61
Rated capacity (R.C.)	1, 2, 3t
Rated output(R.O.)	1.5mV/V ± 0.1%
Non-linearity	≤0.1% R.O.
Hysteresis	≤0.1% R.O.
Non-repeatability	≤0.05% R.O.
Creep error	≤0.05% in 20min.
Zero balance	≤1% R.O.
Compensated temperature range	-10 ~ 70°C
Operating temperature range	-20 ~ 80°C
Temp. effect on rated output	≤0.03% LOAD/10°C
Temp. effect on zero balance	≤0.03% R.O./10°C
Terminal input resistance	700 Ohms ± 3.5 Ohms
Terminal output resistance	700 Ohms ± 5 Ohms
Insulation resistance (Min.)	2000 MOhms at 50V DC
Excitation voltage	10V(Recommended), 15V(Max.)
Electrical connection	Ø5mmx5m(22AWG x 4Core Shielded)
Protection class	meets IP 67
Safe overload	150% R.C
Ultimate overload	300% R.C

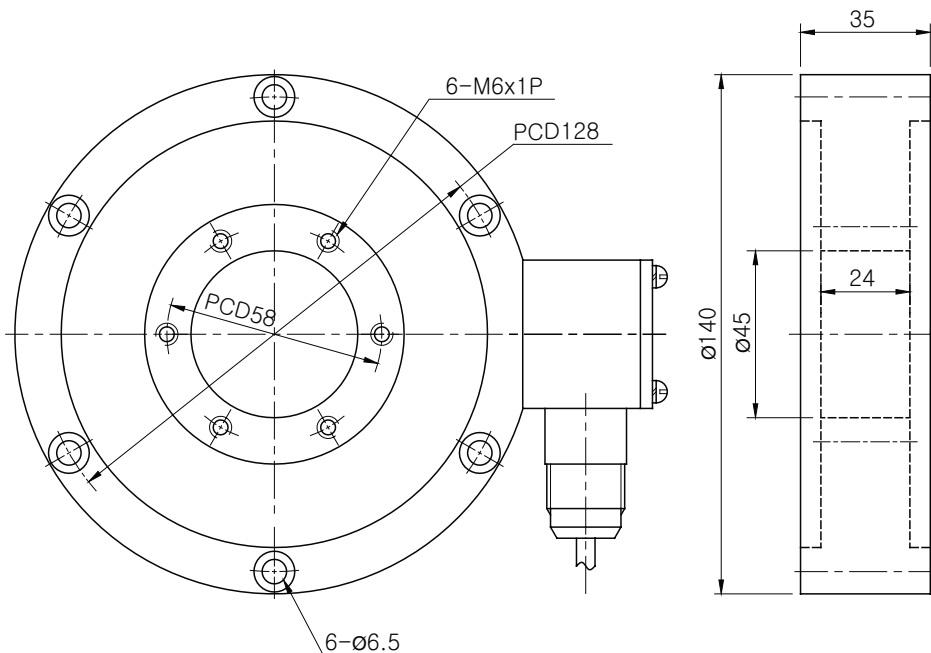

### ORDERING INFORMATION

**CS61 - 2T**

MODEL: CS61      CAPACITY: 1, 2, 3 tf

### WIRING INFORMATION

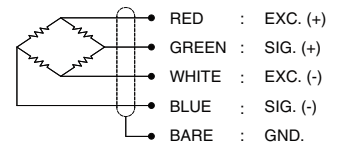

\* Specifications are subject to change without notice

JAN, 2010