

## Model BTV Series

Pillow Block Type Load Cell  
(50kN ~ 100kN)

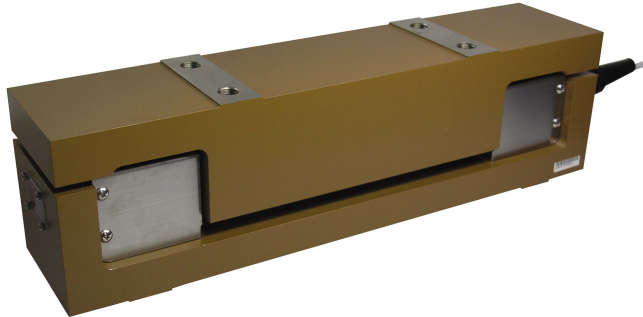

The BTV series, used in metal processing lines and other hostile industrial applications, accurately and reliably measure strip tension, and are designed to mount directly under the roll bearing pillow blocks.

- Overload capability of 400% of rated capacity without zero shift.
- Excellent linearity from zero through the entire measuring range.
- Electroless nickel plated for corrosion resistance and fully sealed to IP67
- Full temperature compensation.

### BTV - 50, 70, 100kN

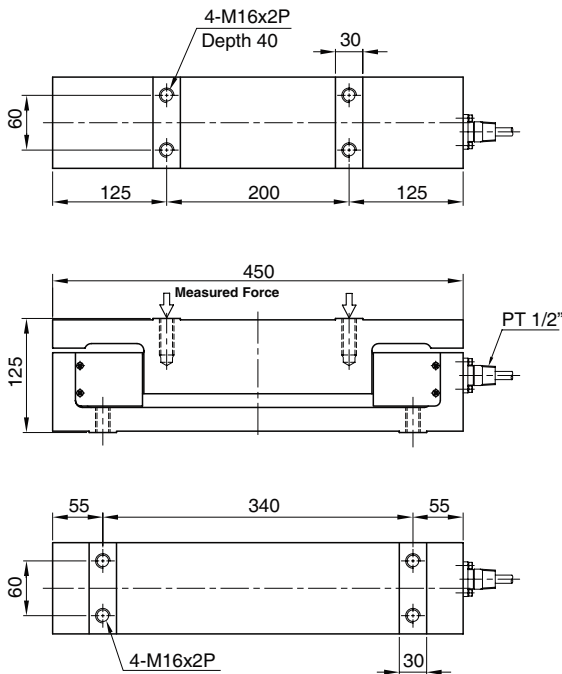

### SPECIFICATIONS

MODEL	BTV
Rated capacity (R.C.)	50, 70, 100kN
Rated output(R.O.)	1.0mV/V ± 0.25%
Non-linearity	≤ 0.2% R.O.
Hysteresis	≤ 0.2% R.O.
Non-repeatability	≤ 0.1% R.O.
Creep error	≤ 0.1% in 20min.
Zero balance	≤ 1% R.O.
Compensated temperature range	-10 ~ 70°C
Operating temperature range	-20 ~ 80°C
Temp. effect on rated output	≤ 0.03% LOAD/10°C
Temp. effect on zero balance	≤ 0.03% R.O./10°C
Terminal input resistance	700 Ohms ± 3.5 Ohms
Terminal output resistance	700 Ohms ± 5 Ohms
Insulation resistance (Min.)	2000 MOhms at 50V DC
Excitation voltage	10V(Recommended), 15V(Max.)
Electrical connection	Ø9mmx6m(22AWG x 4Core Shielded)
Protection class	meets IP 65
Safe overload	450% R.C
Ultimate overload	800% R.C

### ORDERING INFORMATION

BTV	-	50kN
MODEL		CAPACITY
BTV		50kN(5.098tf)
		70kN(7.138tf)
		100kN(10.20tf)

### WIRING INFORMATION

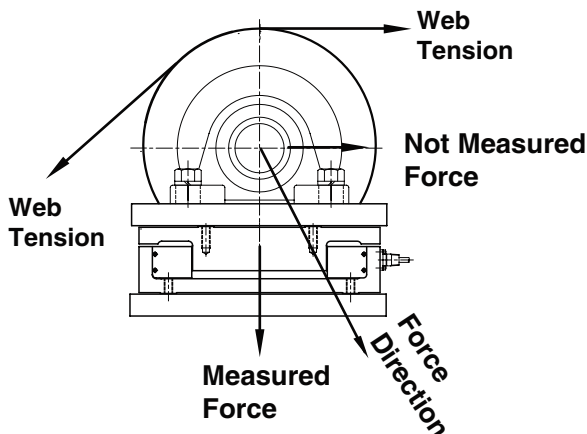
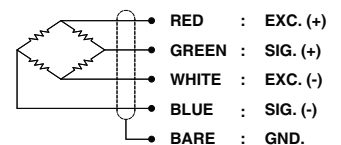

\* Specifications are subject to change without notice

MAR, 2007